

MOTHERCARE PREPARATORY SCHOOLS

ASSESSMENT WORK TERM II - 2020 (SET I)

P.2 ENGLISH

Name: _____ Stream: _____

Branch: _____

SECTION A (1 MARK EACH)

1. Name the pictures below.

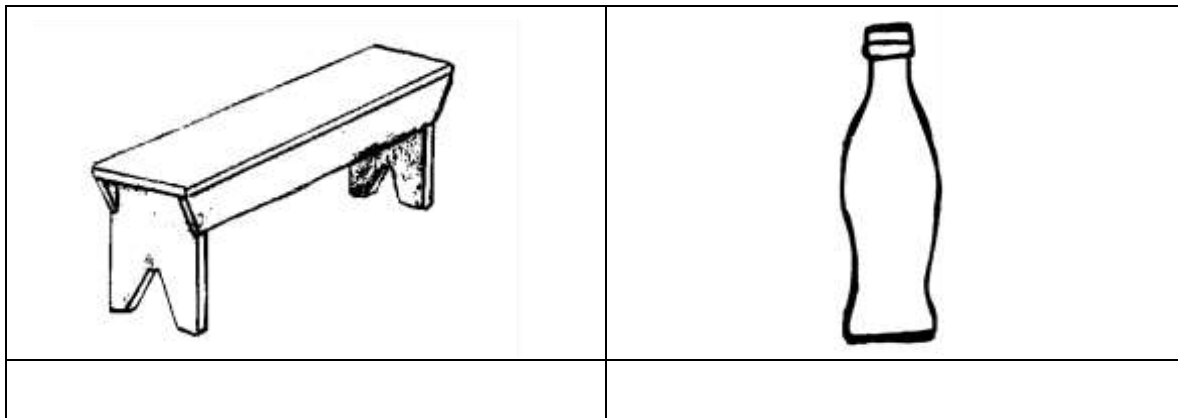

2. Write the opposite of the words in brackets to fill the gaps.

a) The _____ were playing football. (girls)

b) The _____ visited our school last term. (queen)

c) Apio is a _____ girl. (weak)

3. Fill in the missing letters.

a) el__ph__nt

b) sn__ke

4. **Use “has” or “have” to fill the gaps.**

a) I _____ two rabbits.

b) She _____ gone to town.

c) They _____ apples and mangoes.

5. **Write the plural forms of the following words.**

a) cow - _____

b) puppy - _____

c) ox - _____

6. **Use the words in brackets correctly.**

a) They are _____ mango trees. (climb)

b) Kasenene is _____ than Wasswa. (old)

c) We _____ maize yesterday. (plant)

d) Sanyu always _____ porridge at break fast.
(eat)

7. **Complete sensibly.**

a) Baby is to man as _____ is to dog.

b) Teacher is to _____ as doctor is to hospital.

c) Brother is to sister as _____ is to mother.

d) Sitting is to sat as going is to _____ .

8. **Choose the suitable word to fill in the gaps.**

a) _____ is the name of your father? (What , Who)

b) I have _____ eyes. (too , two)

c) Seven days make a _____. (weak , week)

9. **Arrange the words in Alphabetical order.**

a) sheep , pig , cow, ox

b) calf , puppy , kitten, lamb

10. **Re-arrange the words to make correct sentences.**

a) wasp insect is a harmful A .

b) six legs A insect has true.

11. **Write the given short forms in full.**

a) Tue. _____

b) Aug. _____

c) Sch. _____

12. **Make good sentences.**

a) sun : _____

b) son : _____

13. **Give one word for the group of word.**

a) Cows, goats, pigs are _____.

b) Wasps, grasshoppers, ants, cockroach are _____.

c) Bananas, rice, sweet potatoes are _____.

14. **Punctuate the sentences correctly.**

a) the young one of a goat is a kid

b) his sister is aminah

15. **Use a correct word to fill the gaps.**

a) the baby is playing _____ a toy car.

b) A cow lives in a _____.

SECTION B: (2 MARKS EACH)

16. **Answer correctly.**

a)



Where is the boy sitting?

b)



What is on the mat?

c)



How many ropes can you see?

17. **Join the sentences below as instructed in brackets.**

a) Sarah has a ball. Sarah has a rope.
(Join using....and.....)

b) As good as _____. (Complete the simile correctly)

c) Mr. Kabanda is lame. He can ride a bicycle.
(Join using:.....but.....)

d) The teacher gave Sylvia a gift. She performed well.
(Join using:.....because.....)

18. Match animals to their homes.

A

pig
cow
rabbit
fish

B

water
house
sty
kraal

19. **Form five sentences from the table below.**

The potter	makes	a mat.
The driver	weaves	pots.
The woman	drives	cars.
The cyclist	flies	aeroplane.
The pilot	rides	motorcycle.

- a) _____
- b) _____
- c) _____
- d) _____
- e) _____

20. **Arrange the sentences below to form a meaningful story.**

- a) They went home and made pots and cups.
- b) She collected clay soil.
- c) One day, Joy went to the swamp.
- d) On her way home, she met her friend Jalia.
- e) She put it in the pail and carried it home.

Good story

- a) _____
- b) _____
- c) _____
- d) _____
- e) _____

21. **Use the words in the box to fill the story.**

charcoal , cabbages , market , basket, home

Mummy went to the _____. She bought tomatoes_____and onions. She packed them in the _____. The cyclist rode them to our _____. Mummy told me to put _____on the charcoal stove and lit it. She cooked cabbages, they were so delicious.

22. **Read the rhyme and answer questions in full sentences.**

One, two, three, four five, once I caught the fish alive.
Six, seven, eight, nine, ten, then I let it go away.

Why did you let it go?
Because it bit my finger so.
Which finger did it bit?
This little finger on my right.
By Lous.

Questions:

a) Why did Lous let the fish go?

b) Complete correctly.

One, two, three, four, five, once I caught the _____
alive.

c) Who wrote the rhyme?

THE END